

Specialized Cabling for Military Applications

Abstract

This paper outlines the different types of purpose-built connectivity products that are designed to address harsh environment military applications. Several interconnect options are discussed including fiber optic and copper military grade cabling and connectors.



Introduction

Communications systems for use in combat theatre operations require unique considerations compared to non-military, commercial communications systems. Many of the voice, video, and data systems used by the military are mobile and designed for rapid deployment in harsh environments where temperature extremes, shock, vibration, dust, and moisture are prevalent. The constant jostling, vibration, and even major shock experienced in combat could potentially disable a commercial datacom system. Other potential hazards encountered in military operations include heavy EMI and RFI caused by proximity to “noise” generating devices such as motors, switching power supplies, and microprocessors.

When designing a communications network for military applications all the factors listed above must be taken into consideration. Today specialized infrastructure products exist to address the needs of a combat ready military communications system.

Fiber Optics

The use of fiber optic technology in military communications systems provides several benefits, first fiber is immune to EMI and RFI “noise”, secondly fiber can support very long distances before a repeater is necessary, third fiber offers very large bandwidth and can be used in voice, video, and data applications, and lastly the cost of fiber continues to go down as a multitude of manufacturers both domestic and foreign can now produce high quality fiber cabling, connectors, and transceivers.

Fiber Optics for Military applications

Products now exist to address the needs of a military network design. Specialized military connectors such as the Straight Tip (ST) are offered with extra heavy tension springs to assure physical mating will not be compromised in the event of a major shock or vibration. Other variations of the fiber ST connector are available that feature a locking mechanism which prevents optical disconnects in high shock or vibration environments.

Reinforced Military style ST fiber connectors

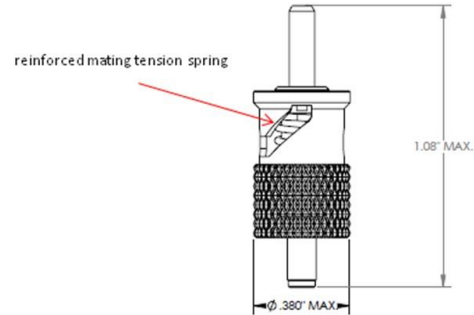

Other militarized fiber optic connectors include Ingress Protection (IP) rated designs that feature extra robust strain reliefs and screw lock mating for solid optical connections even when subjected to shock and vibration. Typical strain relief on these connectors is well over 250 Newton's (56 lbs), which is over 50% better than standard, commercial fiber connector strain relief designs. This added protection ensures the cable assembly will survive incidental contact during the course of field use.

Military/Industrial IP66/67 Plug and Jack



Fiber cable is now also offered in military/industrial styles featuring armored (typically corrugated steel) fiber cable as well as special crush and impact resistant simplex and duplex fiber patch cable designs.

Military style fiber cable options



Impact Resistance: EIA/TIA-455-25
Crush Resistance: EIA/TIA-455-41

Copper Ethernet Cabling: Category 5e/6

Sometimes fiber optic systems cannot be used in military communications systems due to legacy equipment or purely on purpose, by design for whatever reason. In this case category rated copper infrastructure products are required.

Traditional civilian/commercial installations often use the standard unshielded twisted pair (UTP) cabling system which is fine for the controlled environments where most times the cabling is installed and never touched again for years. In the world of military communications applications, UTP systems will not cut it. By coupling shielded twisted pair (STP) cabling and ruggedized military style connectors, most design requirements can be met.

Shielded twisted pair cabling is used to lessen the effects of potentially data damaging EMI and RFI by either reflecting the EMI/RFI or by picking up the interference on the shielding and then conducting it to ground. In order for this shielding to work both shielded cable and shielded connectors must be used and the entire system must be properly grounded.

Example of double shielded (braid and foil) Category 5e cable

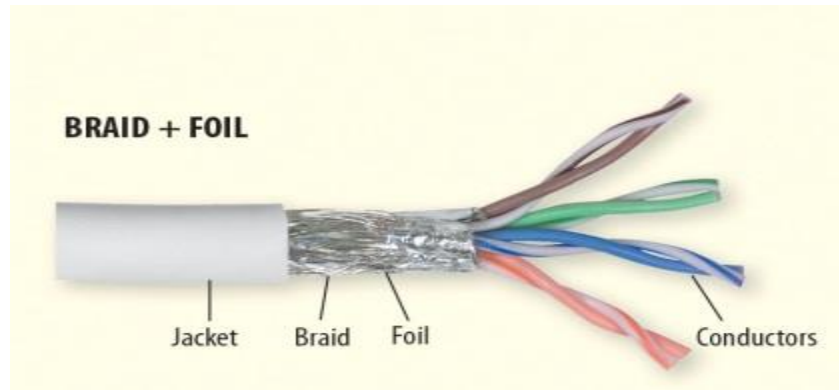

Many styles of military grade category rated connectors exist today including transversely sealed jack and plug options in Zinc Nickel which provides an excellent level of corrosion protection or Anodized finish that also increases corrosion resistance and wear resistance. These types of military connectors feature a compression nut that establishes the cable strain relief thus keeping the connection even when bumped or hit.

Additionally, these types of connectors support 360° shielding when terminated to the cables shielding.

Zinc Nickel and Anodized Mil style RJ45 Plug and Jack



Jacket compounds for both copper and fiber cabling systems

Another consideration when designing cabling systems for military use is the cable jacket compounds. Typical UTP cabling often times utilizes Polyvinyl Chloride (PVC) material in the outer cable jacket. PVC is very toxic when burned and can act as a wick, increasing the spread of fire.

A very popular jacket type used in military cabling system is Low Smoke Zero Halogen (LSZH). LSZH cable produces very little smoke and no Halogens such as Fluorine, Chlorine, and Bromine which can cause harm to expensive communications equipment as well as endanger human lives. LSZH cables will self extinguish and are used extensively in shipboard, aerospace and mobile vehicle applications where confined space communications/networking is prevalent.

Another popular cable jacket type is Polyurethane which stands up to damaging UV rays, is resistant to oils and petroleum-based products, and is very resistant to mechanical abuse where abrasions and cuts are commonplace. One downfall when using Polyurethane jacketed cables is that they give off very toxic gases when burned and do not self extinguish like LSZH cables.

Other types of ruggedized communications solutions

In addition to fiber optic and copper, RJ45 style interfaces, manufacturers are continuing to add other militarized/rugged products to address military communications systems including USB, VGA, and D-Subminiature interfaces.

Ruggedized USB and D-subminiature Connectors

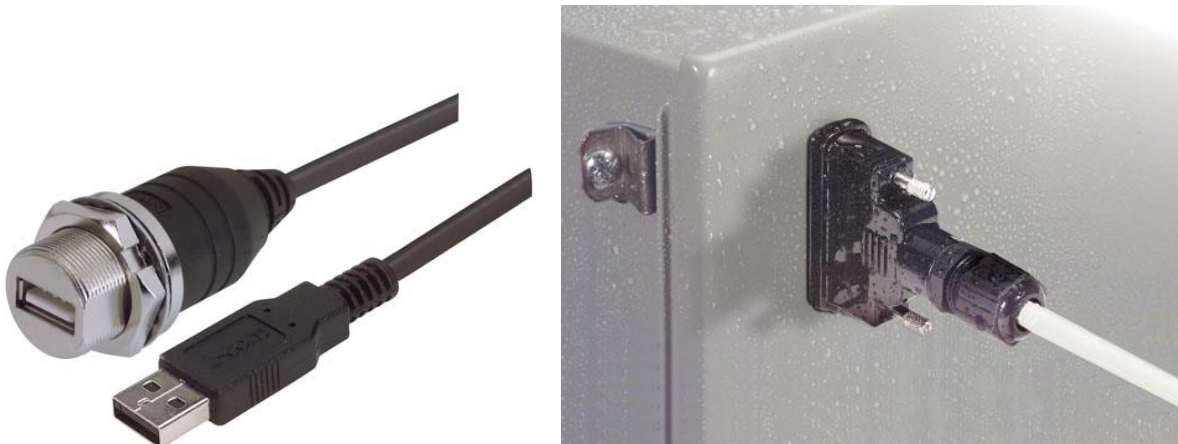



Conclusion

When designing a communications system for a military application several factors must be considered to address the harsh conditions often found in the field. Many commercial off the shelf (COTS) solutions exist today to achieve these design goals.

L-com, a global leader in the manufacture of wired and wireless connectivity products, offers a wide range of solutions and unmatched customer service for the electronics and data communications industries. The company's product portfolio includes cable assemblies, connectors, adapters, computer networking components, and custom products, as well as Antennas, RF Amplifiers, Coaxial lightning and surge protectors, and NEMA rated enclosures. Trusted for over 35 years, L-com, which is headquartered in North Andover, MA, is ISO 9001: 2015 certified and many of its products are UL® recognized. www.l-com.com

For more information, contact your L-com sales representative at 1-800-341-5266 or e-mail sales@L-com.com.



© 2019 [Infinite Electronics, Inc.](http://www.infiniteelectronics.com), L-com is a registered trademark of Infinite Electronics, Inc