

THE INFORMATION CONTAINED IN THIS DRAWING IS THE SOLE PROPERTY OF L-COM, INC. ANY REPRODUCTION IN PART OR WHOLE WITHOUT THE WRITTEN PERMISSION OF L-COM, INC. IS PROHIBITED.

REVISION					
ZONE	REV	DESCRIPTION	DATE	CHANGED BY	APPROVED
	A	INITIAL RELEASE	03/19/2024	SLI	WLI

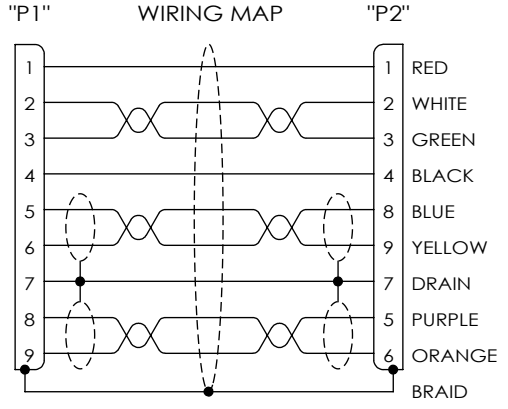
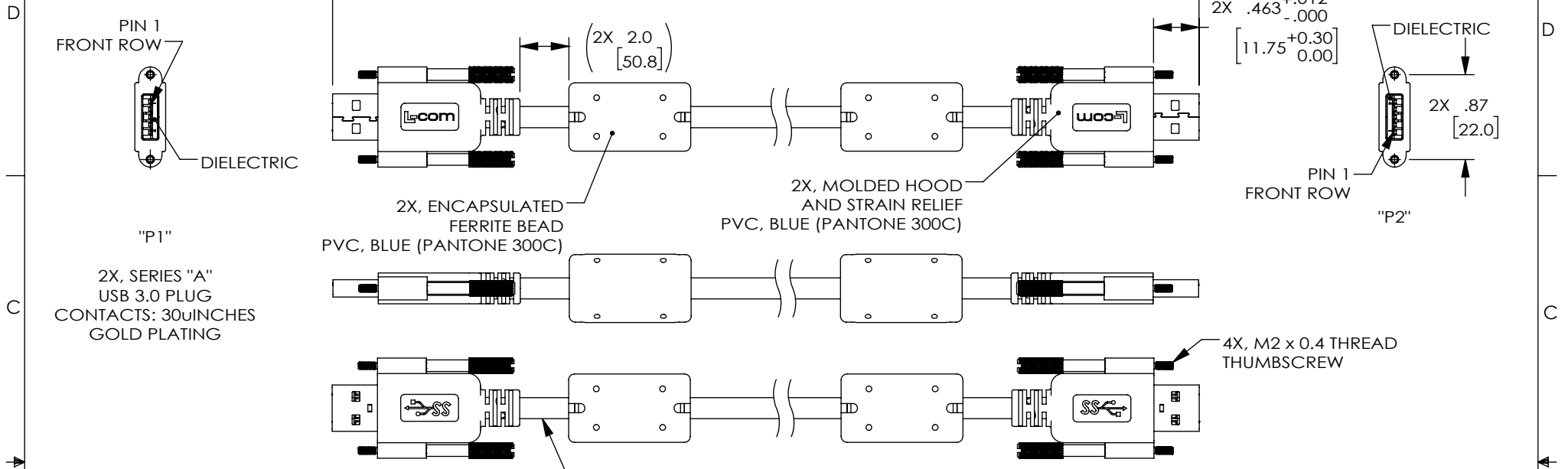

UL STYLE 20276,  
 (2) TWISTED PAIR, 30AWG WITH ALUM/POLY FOIL SHIELD AND DRAIN WIRE,  
 (1) UNSHIELDED TWISTED PAIR, 30AWG,  
 (2) CONDUCTORS, 24AWG, OVERALL ALUM/POLY AND BRAIDED SHIELD,  
 JACKET: PVC, BLUE (PANTONE 300C)  
 (NOM DIA. .217" [5.5], MIN BEND RAD 2.17" [55])

PART NUMBER	LENGTH METERS [FEET]
LCC201002-0.5M	0.5 [1.64]
LCC201002-1M	1.0 [3.28]
LCC201002-1.5M	1.5 [4.92]
LCC201002-2M	2.0 [6.56]
LCC201002-2.5M	2.5 [8.20]
LCC201002-3M	3.0 [9.84]

- NOTES:**
- CABLE ASSEMBLY SHALL BE TESTED FOR CONTINUITY.
  - CABLE ASSEMBLY SHALL HAVE 360° SHIELD TERMINATION.
  - CABLE ASSEMBLY SHALL BE INDIVIDUALLY PACKAGED IN ACCORDANCE WITH L-COM SPECIFICATION PS-0031.

**REGULATORY COMPLIANCE:**  
 EU RoHS DIRECTIVE (MOST RECENT RELEASED VERSION)

UNLESS OTHERWISE SPECIFIED, DIMENSIONS ARE IN INCHES [mm] OVERALL CABLE LENGTH TOLERANCE: ≤12 [305] = +1 [25] / -0 >12 [305] ≤60 [1524] = +2 [51] / -0 >60 [1524] ≤120 [3048] = +4 [102] / -0 >120 [3048] ≤300 [7620] = +6 [152] / -0 >300 [7620] = +5% / -0 ALL OTHER DIMENSIONAL TOLERANCES: .X = ± .2 [5]   FRACTIONS ± 1/32 .XX = ± .02 [5]   ANGLES ± 1° .XXX = ± .005 [1.3]	APPROVALS SLI WLI WLI	DATE 03/04/2024 03/04/2024 03/04/2024	50 High Street, West Mill, North Andover, MA 01845 USA. Phone: 1.800.341.5266 1.978.682.6936	
	CONFIGURATION DETAILS OF UNDIMENSIONED FEATURES MAY VARY	CATEGORY USB		
	COLOR VARIATIONS MAY OCCUR	PRODUCT DESCRIPTION USB 3.0 A THUMBSCREW-A THUMBSCREW WITH FERRITE		
	THIRD-ANGLE PROJECTION 	SIZE A		CAGE CODE 43321
SCALE: NONE		CAD FILE: LCC201002.SLDDRW		SHEET 1 OF 1