

THE INFORMATION CONTAINED IN THIS DRAWING IS THE SOLE PROPERTY OF L-COM, INC. ANY REPRODUCTION IN PART OR WHOLE WITHOUT THE WRITTEN PERMISSION OF L-COM, INC. IS PROHIBITED.

REVISIONS			
REV	DESCRIPTION	DATE	APPROVED
B	ECN1525: CHANGED JACK DESCRIPTION TO 8X8	09/29/03	D. PARHAM
C	ECN1924: CHANGED HOUSING COLOR TO GRAY	12/8/04	D. PARHAM
D	ECN2529: WIRE GAGE WAS 24AWG	08/18/06	D. PARHAM
E	ECN3656: CABLE WAS CAT5 PVC. UPDATED FORMAT	10/21/08	D. PARHAM

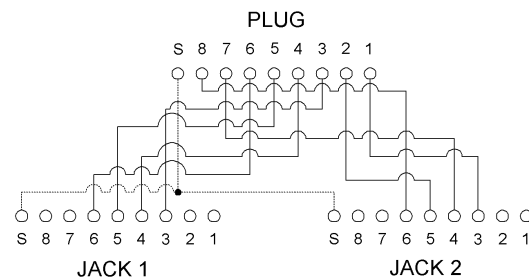

WIRING DIAGRAM LABEL

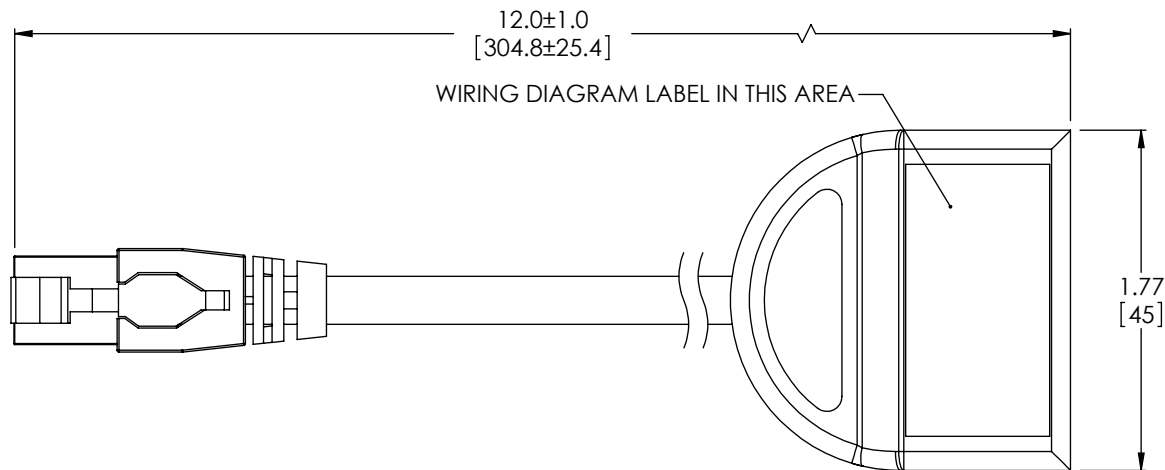
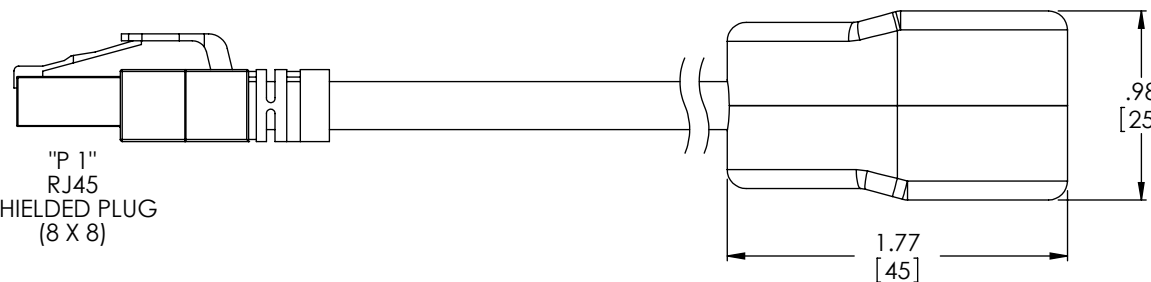

"P 1"
RJ45
SHIELDED PLUG
(8 X 8)

"J1"
RJ45
SHIELDED JACK
(8 X 8)

"J2"
RJ45
SHIELDED JACK
(8 X 8)

ONLY CONTACTS SHOWN IN WIRING
DIAGRAM LABEL TO BE CONNECTED

SPECIFICATIONS

MATERIALS

- PLUG: POLYCARBONATE, UL94V-1
- CONTACTS: PHOSPHOR BRONZE WITH 50 μINCHES GOLD PLATE ON CONTACT SURFACES
- JACKS HOUSING: HIGH IMPACT, FLAME RETARDANT PLASTIC, GRAY, UL94V-0
- CONTACTS: PHOSPHOR BRONZE WITH 50 μINCHES GOLD PLATE ON CONTACT SURFACES
- DURABILITY: 500 CYCLES MIN
- ELECTRICAL
- VOLTAGE RATING: 150VAC
- CURRENT RATING: 1.5 AMP MAX
- DIELECTRIC WITHSTANDING VOLTAGE: 1000Vrms, 1 MIN (60 Hz)
- CABLE: SHIELDED CATEGORY 5e
- 4 TWISTED PAIRS, 26 AWG STRANDED COPPER
- 100Ω NOMINAL IMPEDANCE
- UL LISTED COMMUNICATION CABLE, TYPE CM
- LIGHT GRAY LSZH JACKET

ENVIRONMENTAL
TEMPERATURE: -40°C TO 60°C

UNLESS OTHERWISE SPECIFIED, DIMENSIONS ARE IN INCHES [mm] OVERALL CABLE LENGTH TOLERANCE: ≤12 [305] = +1 [25] / -0 >12 [305] ≤60 [1524] = +2 [51] / -0 >60 [1524] ≤120 [3048] = +4 [102] / -0 >120 [3048] ≤300 [7620] = +6 [152] / -0 >300 [7620] = +5% / -0% ALL OTHER DIMENSIONAL TOLERANCES: .X = .3 .XX = .15 PROJECTION 	APPROVALS DRAWN BY D. PARHAM CHECKED BY B. MAZEJKA APPROVED BY C. McCORMICK	DATE 7/2/2003 7/3/2003 7/3/2003	 45 BEECHWOOD DRIVE NORTH ANDOVER, MA 01845
	CATEGORY MODULAR		PRODUCT DESCRIPTION MODULAR Y SPLITTER
	CONFIGURATION DETAILS OF UNDIMENSIONED FEATURES MAY VARY		
	COLOR VARIATIONS MAY OCCUR	SIZE A	FSCM NO. 43321