

THE INFORMATION CONTAINED IN THIS DRAWING IS THE SOLE PROPERTY OF L-COM, INC. ANY REPRODUCTION IN PART OR WHOLE WITHOUT THE WRITTEN PERMISSION OF L-COM, INC. IS PROHIBITED.

| REVISIONS | | | |
|-----------|--|------------|------------|
| REV | DESCRIPTION | DATE | APPROVED |
| A | INITIAL RELEASE | 07/11/11 | B.PUCHASKI |
| B | CHANGED FINISH BLACK PWDCOAT TO SILVER SB OX (ECN#5662) | 08/11/11 | B.PUCHASKI |
| C | ECN 8362 CHANGE THREAD M3 X .05 TO M3 X .5 | 06/16/16 | B.PUCHASKI |
| D | ECN 9550: REVISED MODEL and DIM. AS PER 1AY06-082 DRAWING SPEC | 01/28/2019 | D.REBECK |

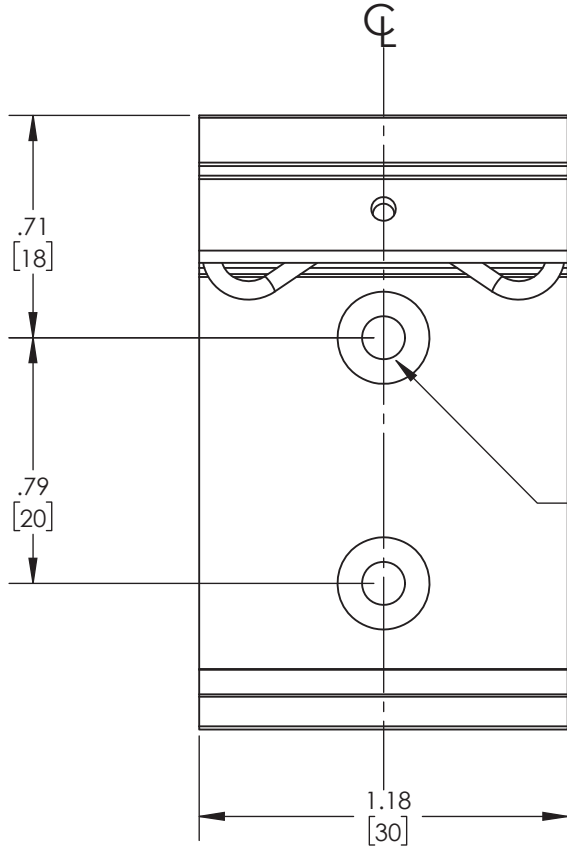

DRILL TRHU AND CS FOR 90° M3 X .5 FLAT HEAD MACHINE SCREW (2X)

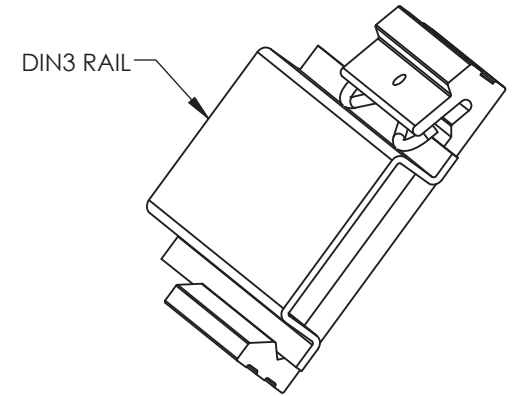
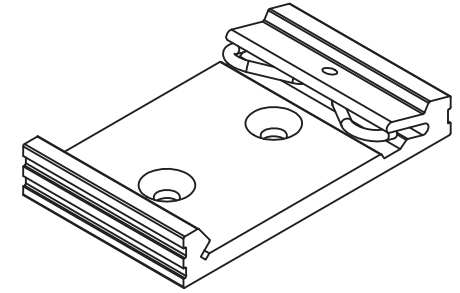
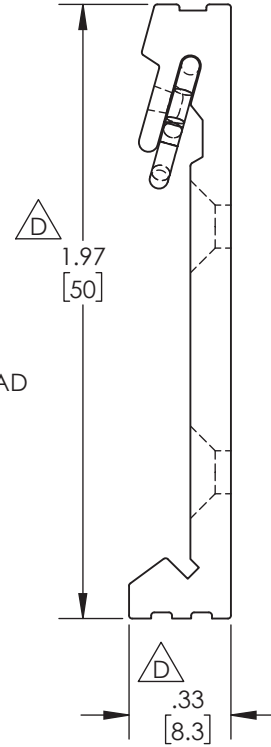

NOTES:
 MATERIAL: ALUMINUM EXTRUSION
 FINISH: SILVER SAND BLASTING OXIDATION
 PACKAGING:
 COMPONENT SHALL BE PACKAGED IN ACCORDANCE WITH L-COM SPEC PKG-00012.

- ALL DIMENSIONS FOR REFERENCE ONLY -

| | | | | |
|--|--|------------------|----------------------------|--|
| UNLESS OTHERWISE SPECIFIED, DIMENSIONS ARE IN INCHES [mm] DIMENSIONAL TOLERANCES: .X = ±.1 [2.54] .XX = ±.01 [.25] .XXX = ±.005 [.13] ANGULAR TOLERANCES: ALL = ± 1° | APPROVALS | DATE | | 50 HIGH STREET NORTH ANDOVER, MA 01845 |
| | DRAWN BY B.PUCHASKI | 05/10/11 | | CATEGORY |
| | CHECKED BY P.PESA | 05/10/11 | PRODUCT DESCRIPTION | |
| | APPROVED BY P.PESA | 05/10/11 | DIN3 RAIL MOUNT CLIP 30 | |
| PROJECTION | CONFIGURATION DETAILS OF UNDIMENSIONED FEATURES MAY VARY | SIZE A | FSCM NO. 43321 | DWG. NO. DIN-MNT30 |
| | COLOR VARIATIONS MAY OCCUR | SCALE: NONE | CAD FILE: DIN-MNT30.SLDDRW | REV. D |
| | | | | SHEET 1 OF 1 |